

THE REVOLUTION IN PELLETISING TECHNOLOGY

Progress MonoRoll HE type 850 x 210



**Guaranteed 20%
energy saving**



**10-15% higher
throughput**



**Optimum pellet
quality**



- Higher steam and liquid addition possible
- No roller slippage resulting in less downtime
- Longer die and roller lifetime
- Lower noise level
- **Payback time 1 - 1.5 year**, at 50,000 t/year, and kWh price € 0.25



Scan the QR code to view our YouTube animation.

Characteristics MonoRoll Pellet Mill:

- Die 850x210 mm
- 1 Large roller $\phi 700$ mm
- Small infeed angle between roller and die
- Low die speed only 4.4 m/s
- Large product layer thickness in the die
- Better pre-compression in the die
- More feed is pushed through the die at once per rotation
- An external cooling system keeps the main bearings at the desired operating temperature

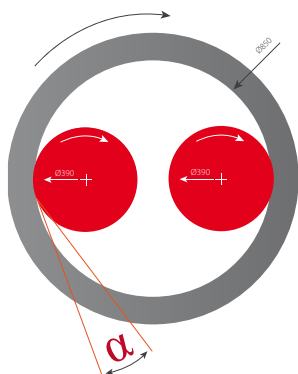

Original type with two rollers

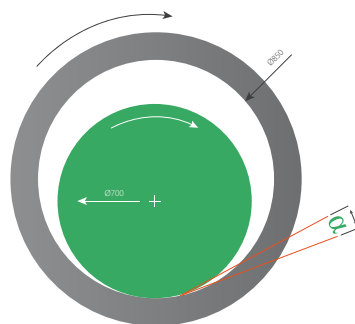

MonoRoll with one roller

This new geometry guarantees a 20% energy saving

Main dimensions Progress 850 x 210 MonoRoll HE
To see our full range of products and solutions, visit www.ptn.nl

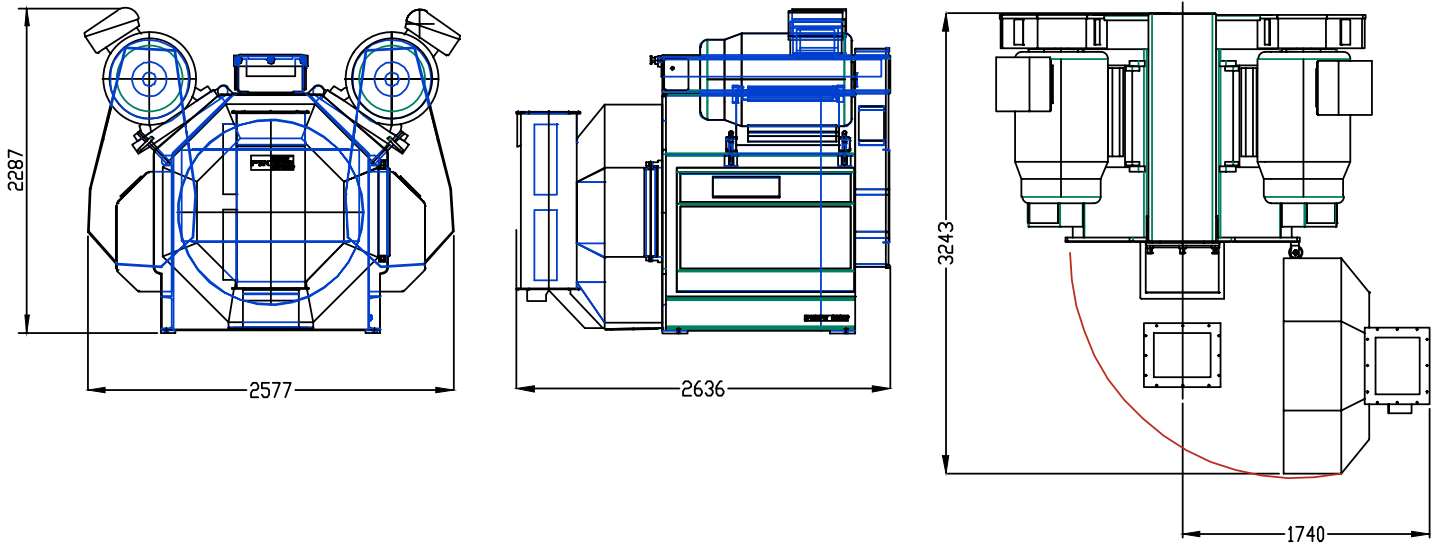

Explore the possibilities. Our specialists look forward to connect and advise.

T: +31 (0)73 54 98 472
E: info@ptn.nl

Pelletising Specialist

PTN manufactures and develops high quality and reliable machines. We strive to offer our customers solutions for:

- Increase profits.
- Reduce costs.
- Leverage the latest technology
- Reduce energy consumption.

As a global specialist in pelleting presses and related machinery, our goal is to be one of the most respected professional OEMs.

